

Flanges

Code F (Galvanised)

Code FR (Nitril Rubber)

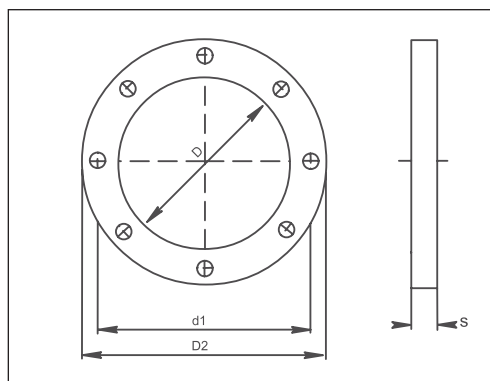

Dimensional specifications are given in the table below

Dimensional Specifications

PRODUCT CODE	Duct		Flange		o	b	n	Weight kg
	Diameter nominal	D mm	d1 mm	D2 mm				
F80	80	83	115	133	3.0	25	9	0.263
F100	100	103	135	153	3.0	25	9	0.313
F125	125	128	160	178	3.0	25	9	0.378
F140	140	143	175	193	3.0	25	9	0.412
F150	150	155	185	205	5.0	25	9	0.545
F160	160	165	195	215	5.0	25	9	0.576
F180	180	185	215	235	5.0	25	9	0.638
F200	200	205	235	255	5.0	25	12	0.700
F225	225	230	260	280	5.0	25	9	0.750
F250	250	255	285	305	5.0	25	9	0.854
F275	275	280	310	330	5.0	25	9	0.958
F300	300	305	336	355	5.0	25	9	1.008
F315	315	320	351	370	5.0	25	9	1.258
F325	325	330	360	380	5.0	25	9	1.460
F350	350	355	389	415	6.0	30	12	1.839
F375	375	380	424	440	6.0	30	9	1.680
F400	400	405	439	465	6.0	30	11	2.080
F425	425	430	462	440	6.0	30	11	1.900
F450	450	455	389	515	6.0	30	11	2.321
F475	475	480	515	540	6.0	30	11	2.130
F500	500	505	540	565	6.0	30	11	2.561
F550	550	535	590	615	6.0	30	11	2.802
F600	600	605	640	665	6.0	30	11	3.043
F630	630	635	670	695	6.0	30	11	3.188
F650	650	655	690	715	6.0	30	11	3.284
F700	700	705	750	785	6.0	40	11	3.525
F750	750	755	800	835	6.0	40	11	5.085
F800	800	805	850	885	6.0	40	11	5.406
F850	850	855	900	935	6.0	40	11	5.727
F900	900	905	950	985	6.0	40	11	6.048
F950	950	955	1000	1035	6.0	40	11	6.370
F1000	1000	1005	1050	1085	6.0	40	11	6.691
F1250	1250	1255	1300	1335	6.0	40	28	6.850

Material

Hot galvanised flat iron

Sizes

80mm to 1250mm diameter

Options

Also available made from Nitril Rubber (Code FR) and compliment our extensive range of flanges. Hardness is 65° shore operates from -10° to 70° resistant to oil, petrol and some acids.

